



## Important Information

The Polaris Vac-Sweep® 280 automatic pool cleaner comes ready to connect to a threaded 1-1/2" female pipe fitting on a dedicated cleaner line. Other connections are possible, **but they require additional fittings** (see Section B on page 4).

The Polaris 280 is intended for use with a Polaris Booster Pump. You should have a licensed electrician install the cleaner's booster pump. **The booster pump must be installed according to the electrical codes applicable in your area.** Improper installation can result in serious or even fatal injury.

The following are important points to remember when installing and operating the Polaris 280.

- Always turn the filtration pump on before turning on the booster pump.
- Always disconnect the Polaris from the pool wall when cleaning or backwashing the pool filter.
- After cleaning or backwashing, let the filtration system run for at least five minutes before reconnecting the Polaris.
- New plumbing lines should be flushed out before installing the Polaris.
- The Polaris should not be used to remove plaster dust in new pools.
- Always remove the Polaris **before swimmers enter the pool.**
- Always handle the Polaris with care. Do not let children or pets play with the Polaris; it is not a toy.
- Except when checking the wheel RPM, do not handle the Polaris while it is operating (see page 7).
- Never pick up the Polaris by the head float.
- Always remove the Polaris from the pool before chemical shock treatments. As a general rule, any pool water that is unsafe for swimming is unsafe for the Polaris.
- Carefully cut the hoses following the instructions on page 5.

By following these simple guidelines, you can help protect against injury and prolong the life of your new Polaris 280.

Before the Polaris is installed, please take a moment to record the serial number. For the location of the serial number, refer to the Exploded Parts Diagram on page 14. You will be asked for this number when you contact our Customer Service Department.

**Serial # C** \_\_\_\_\_

# Table of Contents

- I. Introduction** ..... 3
- II. Installation Instructions** ..... 4
  - A. Polaris 280 Components ..... 4
  - B. Possible Pool Connections ..... 4
    - 1. Dedicated Cleaner Line ..... 4
    - 2. Over-the-deck Installation ..... 4
  - C. Installing the Universal Wall Fitting ..... 4
  - D. Cutting the Feed Hose ..... 5
  - E. Assembling the Polaris ..... 6
  - F. Checking Operation ..... 6
  - G. Fine Tuning ..... 6
    - 1. Thrust Jet Adjustment ..... 6
    - 2. Head Float Adjustment ..... 6
    - 3. Sweep Hose Adjustment ..... 7
    - 4. Universal Wall Fitting Pressure Restrictors ..... 7
    - 5. Checking Wheel RPM ..... 7
- III. Operation and Maintenance** ..... 8
  - A. What to Expect From Your Polaris 280 ..... 8
  - B. Turning On/Off the Polaris ..... 8
  - C. Operating Time ..... 8
  - D. Connecting/Disconnecting the Polaris ..... 8
  - E. Cleaning the Filter Bag ..... 8
  - F. Periodic Maintenance ..... 9
    - 1. Filter Screen ..... 9
    - 2. Wear Rings ..... 9
    - 3. Tires ..... 9
    - 4. Sweep Hose Scrubber ..... 9
  - G. Backwashing the Pool Filter ..... 9
  - H. Storage ..... 9
  - I. Winterizing ..... 9
  - J. Accessories ..... 10
    - 1. Sweep Hose Weight ..... 10
    - 2. Ladder Guard Kit ..... 10
    - 3. WaterStars and WaterStars WF ..... 10
    - 4. Leaf Bag ..... 10
    - 5. Disposable Sand/Silt Bag ..... 10
    - 6. SpaWand ..... 10
- IV. Troubleshooting the Polaris** ..... 11
  - A. Problems and Solutions ..... 11
  - B. Troubleshooting Worksheet ..... 12
- Polaris Booster Pump** ..... 13
- Exploded Parts Diagram** ..... 14
- Warranty** ..... 17

# I. Introduction

Congratulations on the purchase of your new automatic pool cleaner, and thank you for choosing a Polaris Vac-Sweep 280. The Polaris 280 is designed to give you years of dependable and efficient service. With the Polaris 280, you and your family can spend more time enjoying your pool and less time cleaning it.

The Polaris has been built with the finest materials available. The Polaris 280 is backed by the Polaris limited warranty that protects against defects in parts and workmanship (see the warranty on page 17). Like most mechanical devices, it will require periodic adjustments, routine maintenance, and the replacement of certain hardworking parts. Be sure to have the Polaris checked occasionally by your local Polaris dealer.

Always insist on **genuine Polaris replacement parts**. You can be sure you are buying genuine Polaris parts if they come in Polaris part bags or have the Polaris logo  on them. Non-Polaris parts are not made to our specifications. They may have an adverse effect on the operation of your Polaris or may even damage it. If you are unable to find genuine Polaris parts in your area,

contact us at 1-800-VAC-SWEEP (USA and Canada only) or (760) 599-9600 to receive the name of the participating Polaris dealer nearest you.

For best results, the Polaris 280 should be installed by a pool professional. For those with experience and confidence in handling plumbing and mechanical equipment, installation instructions are included in this manual.

**Please Note:** Installation instructions for the Polaris Booster Pump are included with the pump.

➔ *Look for this symbol throughout the owner's manual for helpful hints in the use of your new Polaris 280.*

The numbers in parentheses found throughout the manual refer to the index numbers in the Exploded Parts Diagram on pages 14-16. There are also part numbers listed in parentheses to help identify the replacement parts available at your participating Polaris dealer.

Once again, thank you for choosing a Polaris.

## II. Installation Instructions

### A. Polaris 280 Components

The Polaris 280 box contains (the numbers below refer to the exploded parts diagram on pages 14-16):

1. Sand/Silt Bag (#1)
2. Sweep Hose (#7)
3. Head Float (#4)
4. Cleaner Head
5. Complete Feed Hose
6. Back-up Valve (#53)
7. Sweep Hose Scrubber (#5)
8. Quick Disconnect (#46) with Universal Wall Fitting (#42)
9. Universal Wall Fitting Pressure Restrictors (one red and one blue) (#41)

### B. Possible Pool Connections

#### 1. Dedicated Cleaner Line

A 1-1/2" dedicated cleaner line is recommended. It should be approximately 6" below the water level and have 1-1/2" female threads. If it has 3/4" female threads, you will need to purchase the 3/4" x 1-1/2" coupling (part #G-9).

#### 2. Over-the-deck Installation

If the pool does not have a dedicated cleaner line, the Polaris can be installed by obtaining an over-the-deck kit (part #G-12) and running an aboveground feed line from the booster pump over the pool deck to the pool wall.

### C. Installing the Universal Wall Fitting

1. Turn on the filtration pump and flush out the plumbing line.
2. Remove the universal wall fitting from the quick disconnect. The universal wall fitting has a blue pressure restrictor installed to help the Polaris operate at its optimum level of efficiency. Screw the universal wall fitting and the blue restrictor into the return line by hand.
3. Turn the quick disconnect into the universal wall fitting clockwise and pull away to secure.
4. Turn the quick disconnect by hand to tighten the universal wall fitting; **do not overtighten**. Once the universal wall fitting is secure, the quick disconnect can be removed without removing the universal wall fitting.

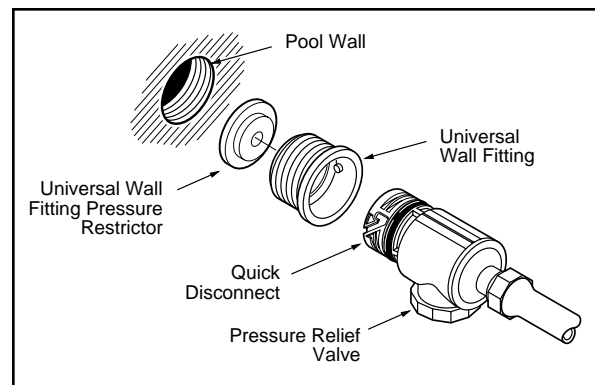

### Properly Sized Feed Hose

For proper cleaner performance, the hose must be sized to fit your pool. To size correctly, follow the steps in Section D. Once sized, the feed hose should look like the one below.

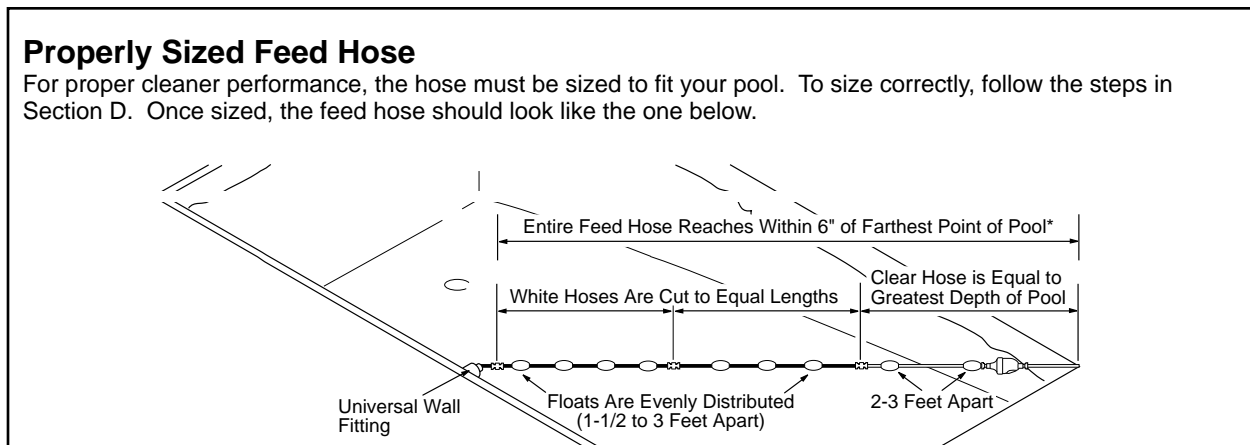

**\*Please Note:** The illustrations in this section do not necessarily represent the farthest point for every pool. You must determine where the farthest point is in your pool.

## D. Cutting the Feed Hose

1. Straighten the feed hose by soaking it in hot water or laying it in the sun.
2. Measure and mark the deepest part of the pool (usually the main drain) with a telepole. **If the pool depth is 10 feet or more, do not cut the clear hose and skip to step 5.**

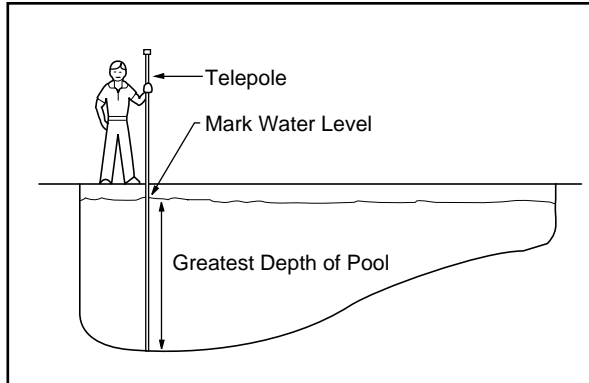

3. Lay the telepole next to the clear hose. If the clear hose is longer than the mark on the telepole, cut the excess from the end attached to the white hose. Do not cut off the float.

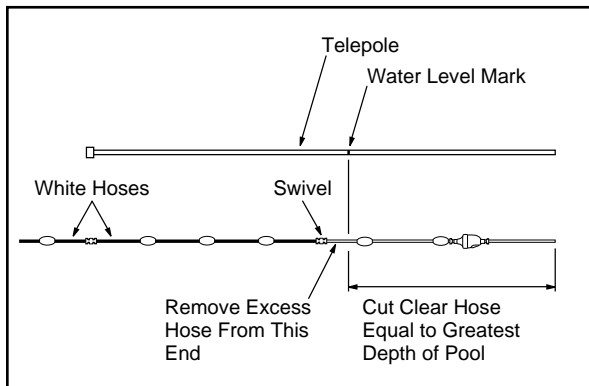

4. Reattach the clear hose to the white hoses.

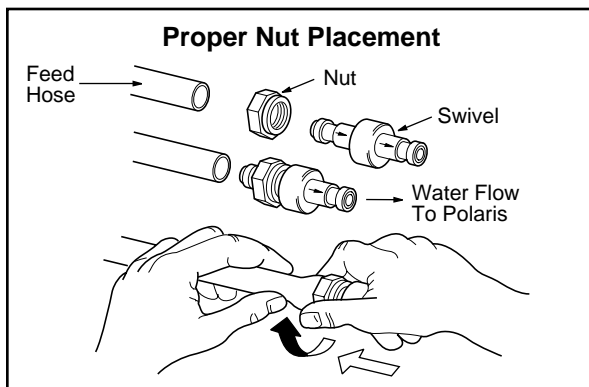

➔ *It is easier to reinstall the swivels when the hose and swivels are wet.*

5. Attach the quick disconnect at the end of the white hose to the universal wall fitting.
6. Stretch the hose to the farthest point of the pool. (The Polaris will not usually climb onto the top step, so do not count it in your measurement.) If the hose is within 6" of the farthest point of the pool, go to Section E.

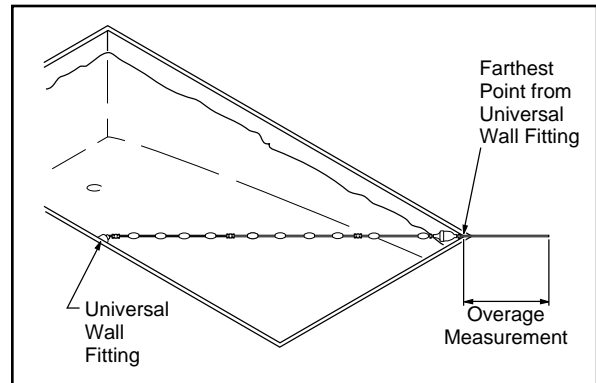

If the hose is more than 6" short, add a 10-foot section of white hose with floats (part #9-100-3104), two nuts (part #D-15), and one swivel (part #D-20). Do not add more than one 10-foot hose section.

7. Measure the amount of hose that extends past the farthest point of the pool. This is the overage measurement. **Do not cut the hose yet.**
8. Lay the hose on the deck. Go to the swivel between the 10-foot white hoses. Slide the floats away from the swivel and remove the swivel.
9. Cut an equal amount of the overage measurement from each 10-foot white hose.
10. Reinstall the swivel with the flow arrows on the swivel pointing toward the Polaris. (Refer to the "Proper Nut Placement" diagram.)

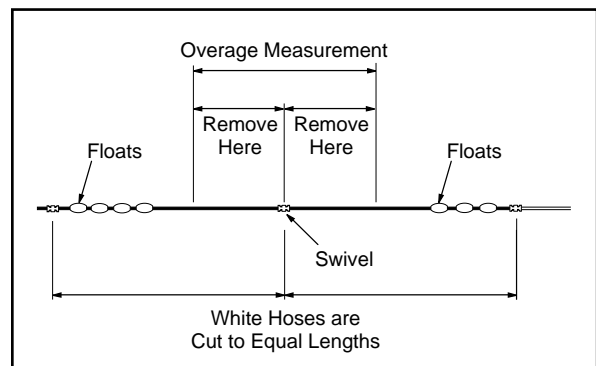

11. On the clear hose, make sure one float is against the back-up valve on the side opposite the cleaner and another float is upstream within 2-3 feet. On the white hoses, space the floats no less than 1-1/2 feet and no more than 3 feet apart, so the white hoses do not sag. It may be necessary to remove floats to maintain proper spacing.

12. When the feed hose has been cut properly, it should look like the one in the "Properly Sized Feed Hose" diagram on page 4.

## E. Assembling the Polaris

1. Put the nut on the feed pipe. Attach the clear hose to the feed pipe and tighten the nut. If there is a curve at the end of the hose, align it with the curve of the feed pipe.

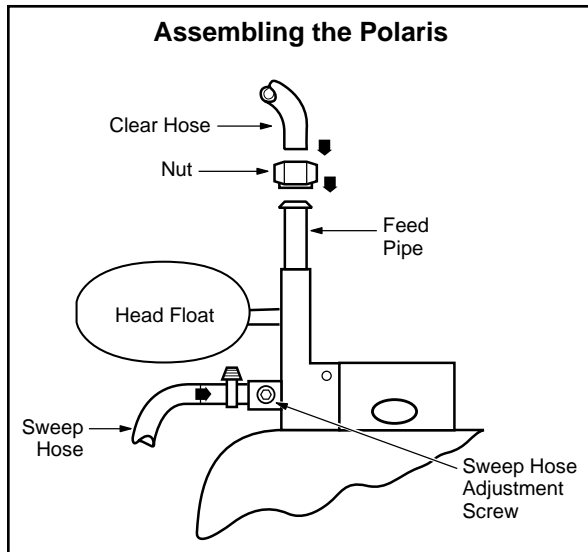

2. Pull out the bag. With the bag on the single-wheel side of the feed hose, snap the bag collar onto the feed hose.
3. Turn on the pool filtration pump. Wait at least 30 seconds and turn on the booster pump.

## F. Checking Operation

When operating correctly, the Polaris 280 will travel randomly throughout the pool, vacuuming, sweeping and scrubbing the bottom, sides, and most of the steps and swimouts. The Polaris will clean an average pool in 3 hours or less.

The Polaris comes equipped with an automatic pressure relief valve in the quick disconnect. If the Polaris is receiving too much water pressure,

it will release water at the quick disconnect. The wheel RPM of the Polaris should be between 28 and 32.

Approximately every 2 minutes the Polaris 280 will go into back-up mode. At this time the back-up valve will pull the Polaris away from potential obstacles and increase its random pattern.

The sweep hose operates in a gentle sweeping motion to prevent debris from becoming trapped in hard-to-reach corners of the pool.

If the Polaris does not operate as described above, turn off the pumps and make the necessary adjustments below.

## G. Fine Tuning

### 1. Thrust Jet Adjustment

The position of the thrust jet determines the direction of the Polaris. Its standard position is straight back.

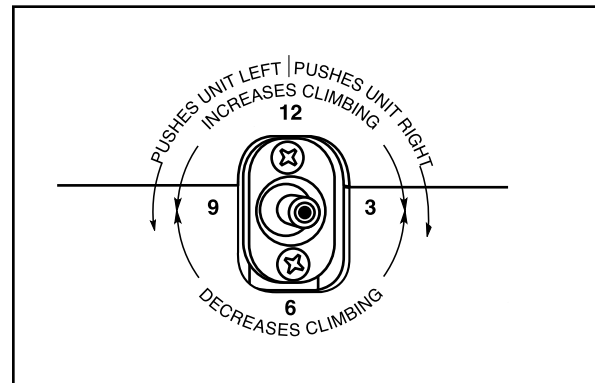

To change the direction of the thrust jet, loosen (but do not remove) the screws, and move the thrust jet to the desired position. Retighten the screws, being careful not to overtighten. For the location of the thrust jet, see the exploded parts diagram on page 14.

### 2. Head Float Adjustment

The head float keeps the cleaner stable and in an upright position. Its standard position is between 1/2 to 1 inch from the feed pipe. Moving the float out from the feed pipe will keep the nose down. Moving the float completely forward, toward the feed pipe, will increase the climbing ability. For the location of the head float, see the "Assembling the Polaris" diagram.

### 3. Sweep Hose Adjustment

The sweep hose should move in a gentle sweeping motion. To decrease its motion, turn the sweep hose adjustment screw clockwise. See the "Assembling the Polaris" diagram on page 6. Make sure the sweep hose scrubber does not block the water flowing from the sweep hose.

### 4. Universal Wall Fitting Pressure Restrictors

The universal wall fitting comes with a blue restrictor installed and an optional red restrictor for use if needed. These special restrictors are designed to work in combination with the pressure relief valve. Together they will release excess water pressure so the Polaris can operate at its optimum level of efficiency. The red restrictor provides maximum water restriction, while the blue restrictor provides less restriction.

To determine whether a restrictor is needed, follow the instructions below.

### 5. Checking Wheel RPM

To determine whether the Polaris is receiving proper water pressure, turn off and carefully remove the Polaris from the pool. Mark the outer edge of a tire. Place the Polaris back in the pool and turn on the pumps.

Hold the Polaris suspended on its side **just below the water level**. Hold it away from the wall with the marked tire up.

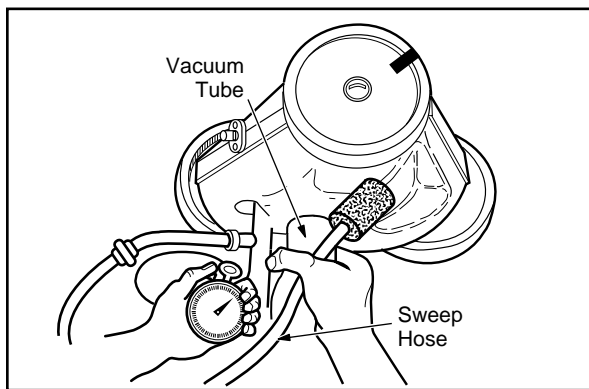

➔ *Hold the sweep hose to avoid being squirted.*

Count the revolutions of the marked wheel for exactly one minute, beginning after the Polaris has completed a back-up cycle. This gives you the cleaner's wheel Revolutions Per Minute (RPM).

For proper operation, the wheel RPM should be **between 28 and 32**.

#### **If the Polaris is operating above 32 RPM:**

- Remove the universal wall fitting by attaching the quick disconnect. Pull it away from the pool wall as you unscrew the universal wall fitting.
- Push the blue restrictor out of the universal wall fitting and snap in the red restrictor.
- Reinstall the universal wall fitting.
- Recheck the wheel RPM.

**If the Polaris is still operating above 32 RPM,** unscrew the pressure relief valve (#43 on page 16) until the proper RPM are reached.

#### **If the Polaris is operating below 28 RPM:**

- Remove the universal wall fitting by attaching the quick disconnect. Pull it away from the pool wall as you unscrew the universal wall fitting.
- Push the blue restrictor out of the universal wall fitting.
- Reinstall the universal wall fitting.
- Recheck the wheel RPM.

#### **If you still have less than 28 RPM:**

- Clean the filter screen in the quick disconnect. A dirty filter screen will restrict the water flow from the pump to the Polaris.
- Check the hoses, connections, and swivels for leaks that could cause loss of water pressure.
- If there is a gate valve installed on the booster pump or the Polaris cleaner line, open it completely so water can flow freely to the Polaris.
- Clean the skimmer and pump baskets.

**Please Note:** If the above suggestions do not work, contact our Customer Service Department.

## III. Operation and Maintenance

### A. What to Expect From Your Polaris 280

When operating correctly, the Polaris 280 will travel randomly throughout the pool, vacuuming, sweeping and scrubbing the bottom, sides, and most of the steps and swimouts. The Polaris will clean an average pool in 3 hours or less.

The Polaris comes equipped with an automatic pressure relief valve in the quick disconnect. If the Polaris is receiving too much water pressure, it will release water at the quick disconnect.

The wheel RPM of the Polaris should be between 28 and 32.

Approximately every 2 minutes the Polaris 280 will go into back-up mode. At this time the back-up valve will pull the Polaris away from potential obstacles and increase its random pattern.

The sweep hose operates in a gentle sweeping motion to prevent debris from becoming trapped in hard-to-reach corners of the pool.

### B. Turning On/Off the Polaris

**Never run the booster pump without the pool filtration pump running.** Turn on the filtration pump. Wait at least 30 seconds and turn on the booster pump. If the Polaris has been installed with time clocks, set them so the Polaris is turned on at least one half hour after the filtration pump has been turned on and shuts off one half hour before the filtration pump shuts off. **Failure to follow these instructions could cause pump damage not covered in the Polaris warranty.**

### C. Operating Time

To find the optimum running time for your pool, start by running the Polaris for 3 hours. Decrease the time until you notice that your pool is not getting clean.

➔ *If you have a lot of debris in your pool (i.e. after a storm), you can run the Polaris in two shorter cycles per day and empty the filter bag between cycles.*

### D. Connecting/Disconnecting the Polaris

To connect, turn off both pumps. Turn the quick disconnect clockwise into the universal wall fitting

and pull away from the pool wall to secure. To disconnect, turn off both pumps. Push the quick disconnect in and turn counterclockwise.

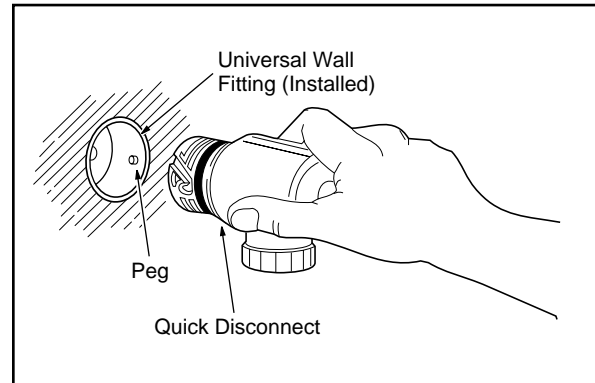

➔ *To make connecting and disconnecting the quick disconnect even easier, periodically lubricate the quick disconnect o-ring with o-ring lubricant.*

### E. Cleaning the Filter Bag

1. Remove the bag collar from the feed hose. Depress the prongs and remove the bag from the cleaner. There is no need to remove the bag collar from the bag.

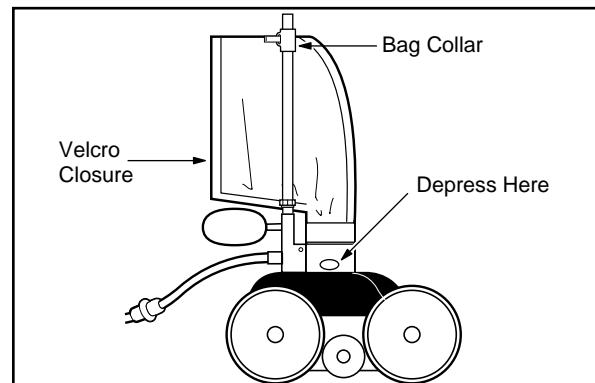

2. Open the velcro closure and dump out the debris.

➔ *If the velcro closure begins to lose its "grip", rinse it, let it dry and clean it with a stiff brush.*

3. Align the prongs and attach the bag to the cleaner. With the bag on the single-wheel side of the feed hose, snap the bag collar on the feed hose.



➔ Some Polaris owners have told us it is easier to empty the filter bag when it is dry. They alternate between two filter bags. When one becomes full, they remove it and put on the clean bag. They let the full bag dry completely before emptying it.

## F. Periodic Maintenance

The following parts are wear items that should be periodically checked and replaced as needed.

**Please Note:** Wear items are not covered under warranty.

### 1. Filter Screen (#43)

Inside the quick disconnect there is a filter screen. It acts as a safety filter to keep any debris that is not caught by the pool filtration system out of the Polaris. If the filter screen clogs often, consult your pool professional.

**Please Note:** Running the Polaris without the filter screen can damage the Polaris.

To clean the filter screen, pull it out of the quick disconnect, rinse it and press it firmly back into place.

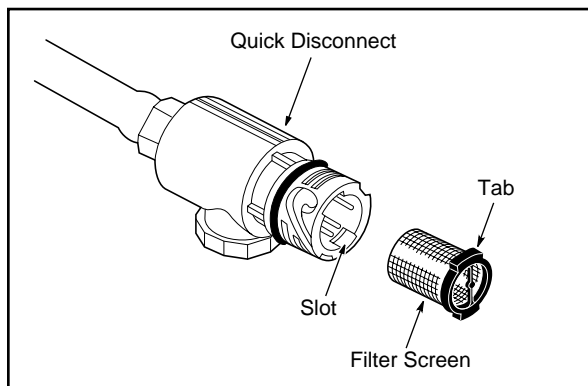

### 2. Wear Rings (#8)

The sweep hose is fitted with rolling wear rings that protect the sweep hose. Replace them before the weights on either side of the wear rings begin to wear.

➔ To maximize the life of the wear rings, we recommend that you rotate them as they wear.

### 3. Tires (#20)

The tires provide traction and protect both the Polaris and the bottom of your pool. Replace the tires when the edges become rounded.

### 4. Sweep Hose Scrubber (#5)

The sweep hose scrubber helps keep the bottom and sides of your pool clean. It also helps prevent the sweep hose from spraying water out of the pool. Replace the scrubber when it becomes worn. The scrubber may need to be replaced often depending on the surface of your pool.

➔ To maximize the life of the sweep hose scrubber, we recommend that you turn it as it wears.

## G. Backwashing the Pool Filter

Always disconnect the Polaris from the pool wall before cleaning or backwashing the pool filter. After cleaning or backwashing, let the pool filtration system run for at least five minutes to flush out the return lines before reconnecting the Polaris.

## H. Storage

Never store the Polaris in direct sunlight or with the feed hose coiled.

➔ If coils do form, lay the hose in the sun or soak it in hot water to help straighten it before reinstalling.

## I. Winterizing

Freeze damage is not covered under warranty. Remove the Polaris from the pool and drain all the water from the Polaris before storing for the winter. Also, drain all the water out of the booster pump by removing the drain plug (see index number 14 on page 13).

Use the quick disconnect to remove the universal wall fitting. Attach the quick disconnect, pull it away from the pool wall and unscrew. In some cases, it may be necessary to use the universal wall fitting removal tool (part #10-102-00) available from your participating Polaris dealer.

**Please Note:** If quick freeze conditions exist, be sure the filtration pump is running and forcing water through the booster pump. If there is a gate valve installed, open it completely so water will flow through the booster pump.

## **J. Accessories**

### **1. Sweep Hose Weight (Part #B-2)**

If the sweep hose or the thrust jet tend to break the surface of the water – squirting nearby windows, pool decking, or innocent bystanders – a sweep hose weight can be installed.

### **2. Ladder Guard Kit (Part #G-21)**

The ladder guard kit will help prevent the Polaris from getting hung up around the pool ladder or handrails.

### **3. WaterStars (Part #7-400-00) and WaterStars WF (Part #11-100-00)**

Both of the Polaris WaterStars fountains come equipped to connect to a universal wall fitting. Once the Polaris 280 is installed with the universal wall fitting, you can quickly and easily switch from pool cleaner to Polaris fountain and back again.

### **4. Leaf Bag (Part #K-15)**

The leaf bag is a large bag made of a more durable material. It is specifically designed to collect larger, heavier types of debris such as large quantities of leaves and acorns. It can be especially helpful after a storm.

### **5. Disposable Sand/Silt Bag (Part #G-45)**

The disposable bags are used in conjunction with any of the other bags. They are made of an ultra fine material that will help catch even the finest silt. They will also make cleaning your bag even easier. Disposable bags are sold in packs of four.

### **6. SpaWand (Part #5-100-00)**

This simple, effective hand-cleaning device allows you to rapidly clean your spa without hoses or hookups. It's also great for fish ponds and other small bodies of water.

## IV. Troubleshooting the Polaris

For best results, follow the troubleshooting solutions in the order they are listed below. The numbers in parentheses refer to the Exploded Parts Diagram on pages 14-16.

### A. Problems and Solutions

**Problem:** Hangs up on corners or obstacles longer than 2 minutes.

**Solution:**

1. Check the wheel RPM. See page 7.
2. Make sure the back-up valve pulls the Polaris back approximately every 2 minutes.
3. Adjust the thrust jet (#23). See page 6.
4. Remove unnecessary pool hardware or install a ladder guard kit (part #G-21). See page 10.

**Problem:** Sweep hose sprays too much water out of the pool.

**Solution:**

1. Check the sweep hose scrubber (#5) and replace it if it's worn or missing (part #9-100-3105).
2. Decrease the sweep hose action. See "Sweep Hose Adjustment" on page 7.
3. Add a sweep hose weight (part #B-2). See page 10.

**Problem:** Polaris goes in circles and does not clean the entire pool.

**Solution:**

1. Check the wheel RPM. See page 7.
2. Adjust the thrust jet (#23) to make the Polaris go in more of a straight direction. See page 6.

**Problem:** Polaris will not climb walls.

**Solution:**

1. Check the wheel RPM. See page 7.
2. Position the thrust jet (#23) to 12:00 o'clock for maximum climbing ability. See page 6.
3. Push the head float forward toward the feed pipe. See page 6.
4. Verify that the rear wheel is being driven by the idler wheel. If not, push the idler wheel (#24) downward to dislodge any sand or dirt. If it will still not move freely, remove the wheel

screw (#18) and pull the idler wheel off the axle. Clean away any debris caught under the wheel. It may help to move the swing axle (#28) downward several times. Reattach the idler wheel.

**Problem:** Sweep hose is sucked into the vacuum tube.

**Solution:**

1. Make sure the opening at the end of the sweep hose (#7) is not blocked by the sweep hose scrubber (#5).
2. Adjust the sweep hose (#7) to a gentle sweeping motion. See page 6.

**Problem:** Polaris runs on its side.

**Solution:**

1. Empty the bag (#1).
2. Check the head float (#4). If it's full of water, remove and replace it (part #A-20).
3. Check the floats (#50) on the feed hose to make sure they are floating and spaced evenly. See the "Properly Sized Feed Hose" diagram on page 4.

**Problem:** Feed hose tangles or ties itself in knots.

**Solution:**

1. Make sure the feed hose has been cut properly. See page 5.
2. Check the floats (#50) to make sure they are floating and spaced evenly. See number 11 on page 6.
3. Check the wheel RPM. See page 7.
4. Make sure the swivels (#49) are turning freely and the flow arrows on all of the swivels are pointing toward the cleaner.

**Problem:** Polaris will not stay on the bottom; it floats around the pool.

**Solution:**

1. Check the wheel RPM. See page 7.
2. Move the head float away from the feed pipe.
3. Empty the sand/silt bag.
4. Verify the feed hose length and float placement. See page 5.

**Problem:** Polaris moves too slowly.

**Solution:**

1. Check the filter screen (#43) in

the quick disconnect and clean, if necessary.

2. Clean the skimmer, pool filter and pump basket if they are dirty.

3. Check all of the hoses for holes that could cause loss of water pressure.

4. Verify that the rear wheel is being driven by the idler wheel. If it is not, refer to step 4 under "Polaris will not climb walls" on page 11.

5. Make sure the Polaris is receiving adequate water pressure. See number 5 on page 7.

**Problem:** The feed hose keeps disconnecting from the wall fitting.

**Solution:** 1. Make sure the quick disconnect is firmly attached to the pool wall. Align the two tracks on the quick disconnect with the two inner pegs of the universal wall fitting. Twist clockwise 1/4 turn and pull away from the pool wall to secure.

2. Check the universal wall fitting to ensure that the inner pegs are not damaged.

**Problem:** The feed hose keeps disconnecting at the swivels.

**Solution:** The nuts may have been installed backwards. See the "Proper Nut Placement" diagram on page 5.

**Please Note:** It is important to use genuine Polaris replacement parts, because non-Polaris parts may adversely affect the unit's performance. Filter bags are an excellent example; "generic" bags are not specifically designed to work with the Polaris and can cause operating problems.

## B. Troubleshooting Worksheet

If none of the troubleshooting solutions worked, please fill in the following information and either contact your participating Polaris dealer or our Customer Service Department at 1-800-VAC-SWEEP (USA and Canada only) or (760) 599-9600. Monday through Friday, 7:30 a.m. - 5:00 p.m. PST.

In order to provide faster and more convenient service, have the following information available at the time of your call or when taking the Polaris in for service.

1. **Serial #:** \_\_\_\_\_

(See page 14 for the location of the serial #.)

2. **Wheel RPM:** \_\_\_\_\_

(See page 7.)

3. **Is the back-up valve cycling?**

(Watch the jet on the back-up valve. It should come on and go off. It should stay off longer than it stays on.)

Yes       No

4. **Is the hose the proper length?**

(See the diagram at the bottom of page 4.)

Yes       No

Length of the clear hose: \_\_\_\_\_

Length of the white hoses: \_\_\_\_\_

5. **Is the hose floating properly?**

(See number 11 at the top of page 6.)

Yes       No

6. **How often do you clean the filter screen inside the quick disconnect?** (See page 9.)

Never       Once a week

Twice a week       Once a month

7. **Are the vacuum jets obstructed?**

(While the cleaner is operating, hold it upside down and look into the vacuum tube. There should be two distinct, even jets of water.)

Yes       No

# Polaris Booster Pump - Sold Separately

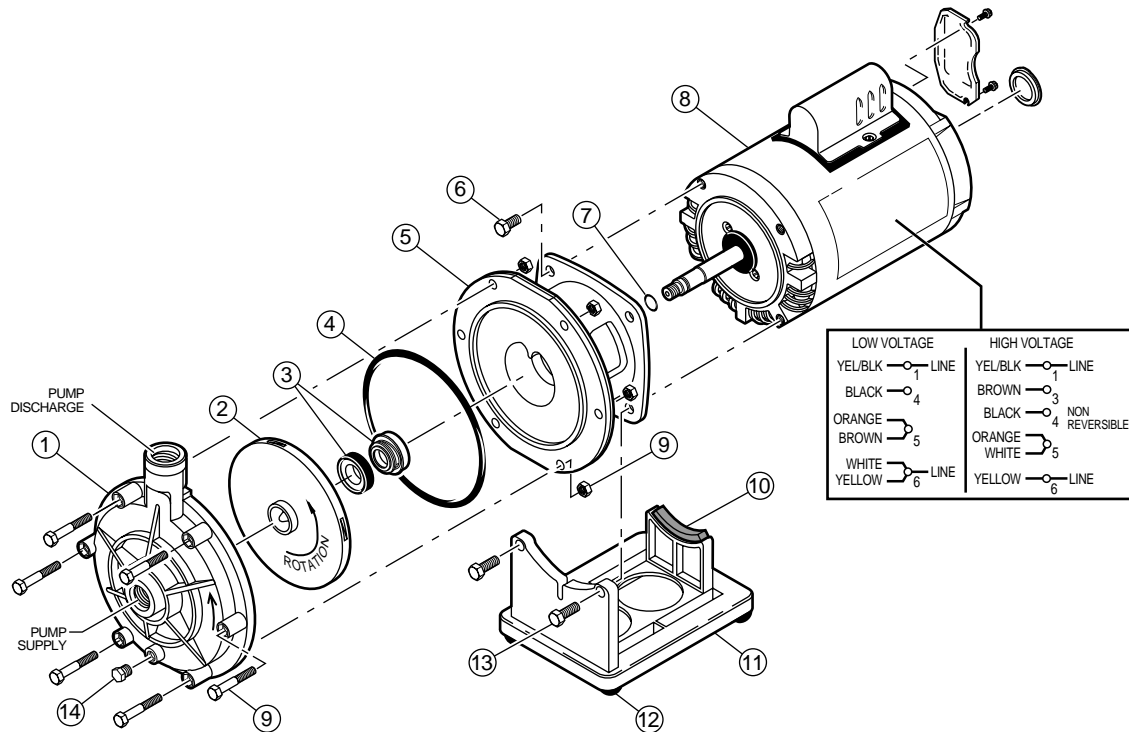
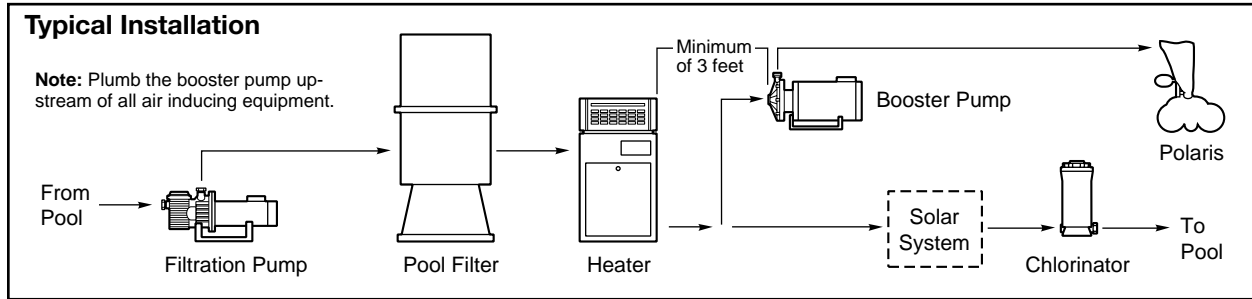

No.	Part #	Description	Qty
1	P-5	Volute (Includes drain plug)	1
2	P-15	Impeller	1
3	P-55	Seal, Stainless Steel Cup/Spring	1
4	P-95	O-ring, Bracket	1
5	P-10	Bracket	1
6	P-35	Bolt, Stainless, Bracket to Motor	2
7	P-40	O-ring for Shaft	1
8	P-61	Motor, 3/4 HP, Threaded Shaft	1
9	P-25	Bolt/Nut, Stainless, for Volute to Bracket	6
10	P-80	Rubber Strip, Motor/Bracket	1
11	P-70	Pump Stand with Feet, Strip	1
12	P-75	Rubber Feet	4
13	P-65	Bolt, Stainless, Stand to Bracket and Motor	2
14	P-20	1/8" NPTM Plug, Plastic	1

**PLEASE NOTE:** All of the parts fit the PB3 Booster Pump produced in 1978 except P-20 and P-25. Call 1-800-VAC-SWEEP (USA and Canada only) or (760) 599-9600 for more information on the Polaris Booster Pump.

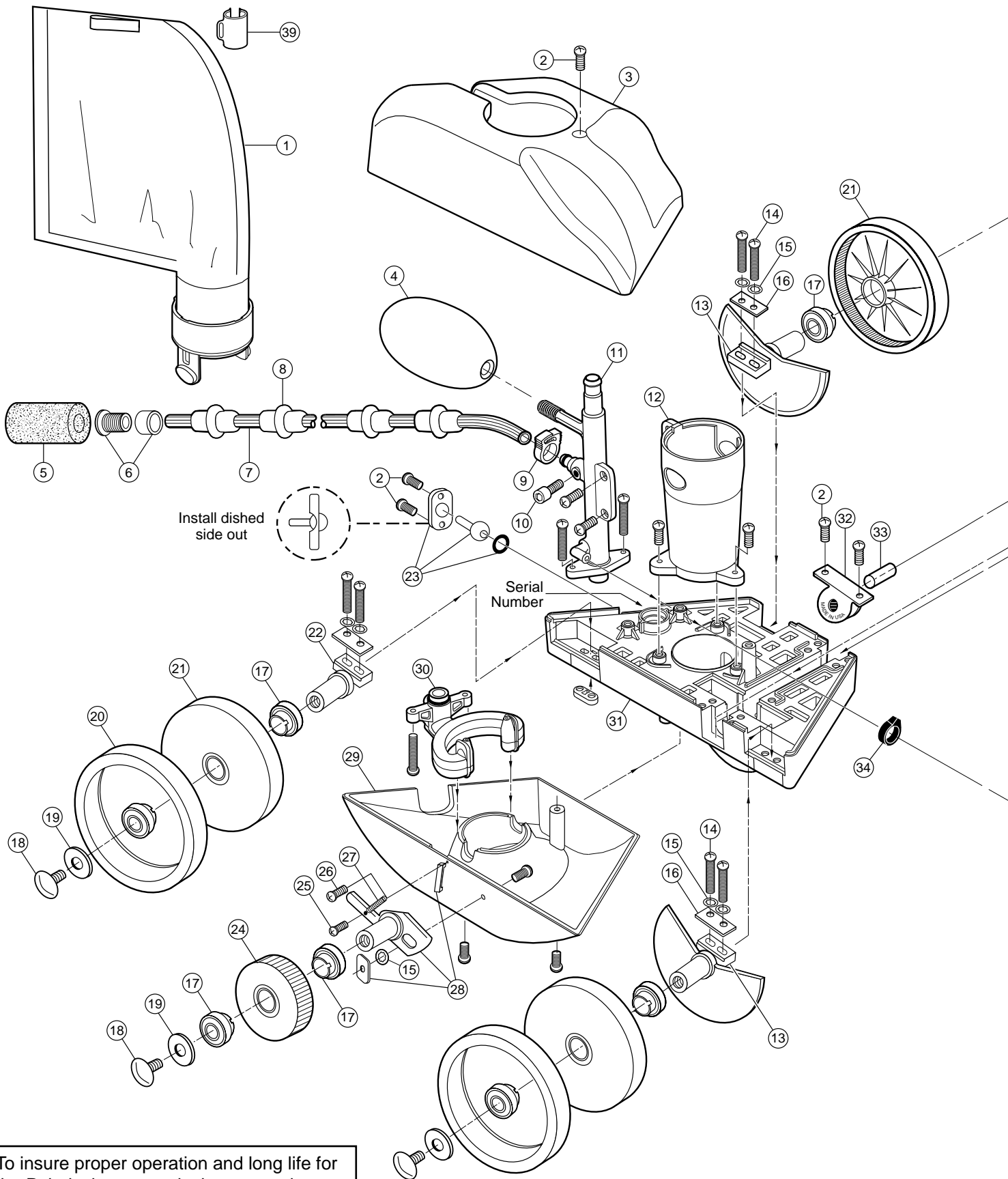

To insure proper operation and long life for the Polaris, be sure to insist on genuine Polaris parts.

# Polaris280

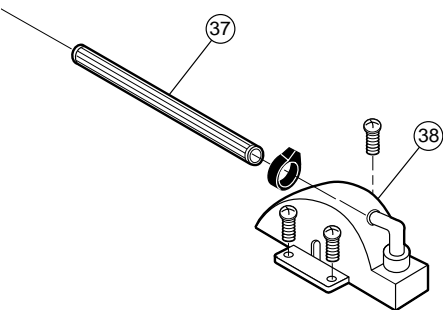
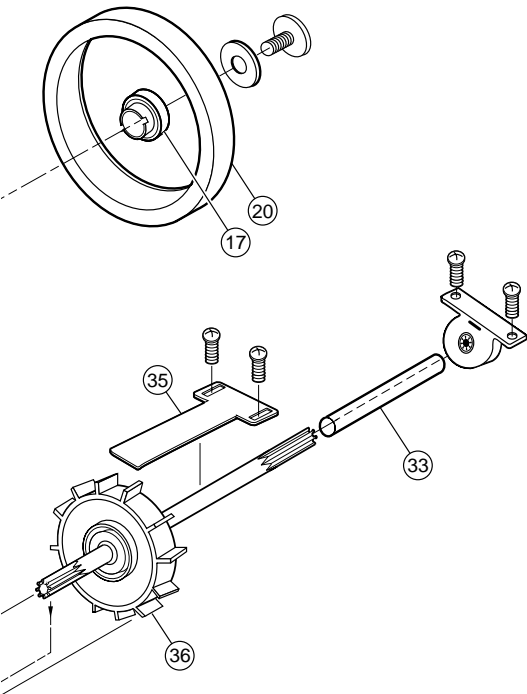

No.	Part #	Description	Qty
1	K-16	All-Purpose Bag	1
2	C-40	Screw, SS 10-32 x 3/8" Pan Hd	20
3	K-5	Top, Blue	1
4	A-20	Float, Head	1
5	9-100-3105	Sweep Hose Scrubber	1
6	B-25	Orifice Tip w/Orifice Tip Guard	1
7	B-5	Sweep Hose Complete	1
8	B-10	Wear Rings	8
9	B-15	Sweep Hose Attach Clamp, White	1
10	B-20	Adjustment Screw, Sweep Hose	1
11	K-30	Feed Pipe with Elbow	1
12	K-20	Vacuum Tube	1
13	C-66	Axle, Large (with Sand/Gravel Guard)	2
14	C-76	Screw, SS 10-32 x 7/8" Pan Hd	10
15	C-45	Lock Washer for C-36	7
16	C-70	Axle Plate for C-65/C-66	3
17	C-60	Ball Bearings, Wheels	8
18	C-55	Wheel Screw, Plastic	4
19	C-64	Wheel Washer, Plastic	4
20	C-10	Tire, White	3
21	C-6	Wheel, Large (No Bearings)	3
22	C-65	Axle, Large (Rear Wheel Only)	1
23	C-131	Thrust Jet Kit	1
24	C-16	Idler Wheel, Small, White	1
25	C-30	Screw, SS 4-40 x 3/16" Pan Hd	1
26	C-32	Screw, SS 6-32 x 1/2" Pan Hd	1
27	C-25	Spring for C-36	1
28	C-36	Swing Axle Kit	1
29	K-10	Bottom, White with Bracket	1
30	K-25	Water Management System	1
31	K-145	Frame, Exchange Only	1
32	C-80	Ball Bearings, Turbine	2
33	C-83	Turbine Shaft Tubes	1
34	9-100-7170	Hose Clamp for WMS	2
35	A-40	Turbine Shaft Shield	1
36	C-86	Drive Shaft Assembly	1
37	C-120	Hose for C-110, 7 1/2"	1
38	C-110	Turbine Cover with Elbow	1
39	9-100-1018	Collar, Bag	1

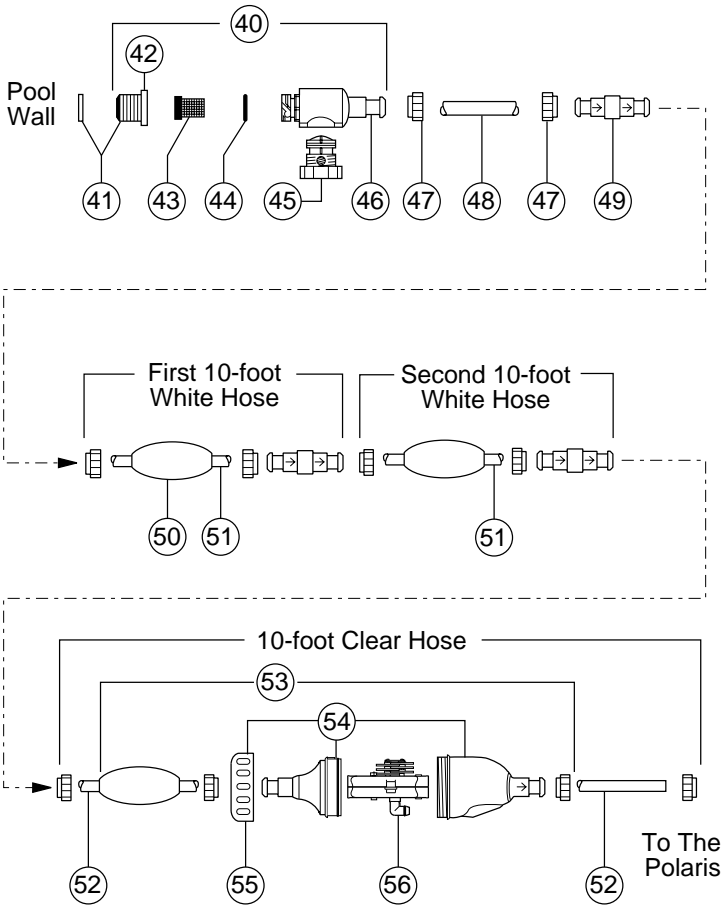

No.	Part #	Description	Qty
40	9-100-9001	UWF Connector Assembly	1
41	10-108-00	UWF Restrictor Kit	1
42	6-500-00	Universal Wall Fitting	1
43	6-504-00	Filter Screen, UWF/QD	1
44	6-505-00	O-ring, UWF/QD	1
45	9-100-9002	Pressure Relief Valve, Black	1
46	D-29	Quick Disconnect, UWF	1
47	D-15	Nut, Feed Hose	10
48	*	Adapter Hose, 8 1/2"	1
49	D-20	Swivel, Ball Bearing	3
50	D-10	Float, Feed Hose	9
51	D-45	Feed Hose, White, 10 Foot, Hard	2
52	D-50	Feed Hose, Clear, 10 Foot, Soft	1
53	G-52	Back-up Valve Kit	1
54	G-54	Case Kit for G-52	1
55	G-57	Collar, Back-up Valve	1
56	G-53	Mechanism for G-52	1
<b>Parts Not Shown</b>			
	B-2 C-11 G-5	Weight, Sweep Hose Tire, Black Feed Hose Complete w/UWF, No Back-up Valve	
	G-9 G-12 G-21	Coupling, 1 1/2" NPTF x 3/4" NPTM Over-the-deck Kit, UWF Ladder Guard Set, 2 Panels	
	G-45 K-15 9-100-3104	Sand/Silt Bags, Pkg. 4, Disposable Leaf Bag Feed Hose with Floats, White	
	9-100-3108 11-203-00	Feed Hose with Floats, Clear Adjustable Plug, UWF	

\*Not sold separately.



## **Limited Warranty**

### **Polaris Vac-Sweep® 280 Automatic Swimming Pool Cleaner**

This limited warranty is extended to the original consumer purchaser of this Polaris Vac-Sweep® 280 Automatic Swimming Pool Cleaner manufactured by Polaris Pool Systems, Inc., 2620 Commerce Way, Vista, California 92083-8438, USA.

Polaris warrants the cleaning unit it manufactures, including all parts and components thereof, to be free of defects in material and workmanship. The booster pump is excluded in this warranty and carries its own separate warranty. We do not cover bags, tires, sweep hoses or sweep hose scrubbers which have been worn out by use. These are normal replacement items. We do not cover improper installation of the Polaris 280, but our instruction manual is complete enough to solve any problems — particularly if it is read before, rather than after, the installation. If you have any questions regarding your Polaris 280, please feel free to write us. Be sure to include the serial number of your unit.

The warranty commences on the date of installation of the Polaris. The Polaris 280 frame is warranted for a period of five years. The rest of the Polaris parts are warranted for a period of one year, but in no event shall be in effect for more than two years from the date of manufacture of the unit as established by the serial number. The one year limited warranty will be extended to two years from the date of installation if you return your completed warranty registration card to Polaris.

This limited warranty does not apply if the failure is caused or contributed to by any of the following: improper handling, improper storage, winter freezing, abuse, improper installation, removal of the UWF filter screen, unsuitable application of the unit, lack of reasonable and necessary maintenance, or repairs made or attempted by other than Polaris or one of its Authorized Service Centers. Polaris will repair or replace, at its option, a unit or part proved to be defective within the warranty period and under the conditions of the warranty.

The consumer must deliver or ship the unit or warranty parts freight prepaid to the nearest Polaris Authorized Service Center or return it freight prepaid (after proper authorization) to the plant of manufacture. Authorization to return a unit or part to the plant of manufacture must be obtained from the Polaris Customer Service Department. Check with your dealer for the local procedure before exercising this warranty. If further directions or instructions should be required, contact the Customer Service Department at 1-800-VAC-SWEEP (USA and Canada only) or (760) 599-9600. Be sure you insure your shipments against loss or damage in transit.

Polaris is not responsible for the cost of removal of the unit or part, damages due to removal, or any other expenses incurred in shipping the unit or part to or from the factory or its Authorized Service Centers, or the installation of the repaired or replacement unit. The consumer must bear these expenses.

This warranty does not cover repair or replacement of a unit or part except at our factory or a Polaris Authorized Service Center.

**THIS LIMITED WARRANTY IS IN LIEU OF ALL OTHER WARRANTIES, EXPRESS OR IMPLIED, INCLUDING THE IMPLIED WARRANTIES OF MERCHANTABILITY AND FITNESS FOR A PARTICULAR PURPOSE, AND ALL SUCH OTHER WARRANTIES ARE DISCLAIMED EXCEPT TO THE EXTENT ANY IMPLIED WARRANTY MAY BE IMPOSED BY STATE CONSUMER LAW. ANY SUCH IMPLIED WARRANTY IMPOSED BY STATE CONSUMER LAW IS LIMITED IN DURATION TO ONE (1) YEAR FROM DATE OF PURCHASE.**

**IN NO EVENT SHALL POLARIS BE LIABLE FOR INCIDENTAL OR CONSEQUENTIAL DAMAGES OF ANY NATURE OR KIND OR FOR DAMAGES TO PERSONS OR PROPERTY, INCLUDING ANY DAMAGE RESULTING FROM THE USE OF THE POLARIS 280 AUTOMATIC POOL CLEANER WITH A SUBSTANDARD POOL CIRCULATION SYSTEM.**

Some states do not allow limitations on how long an implied warranty lasts, or the exclusion or limitation of incidental or consequential damages, so the above limitations may not apply to you.

This limited warranty is valid only in the United States of America, Canada and Australia, and it does not apply to Polaris 280 Automatic Swimming Pool Cleaners sold or installed in any other country.



