

# Installation Instructions

(for part no:s HD100SN, HD100N,  
HD100LAK, HD1001SCS, HD1001CS,  
HD1001SLS, HD1001LS, HD101LS)



**Skimmers**

# Skimmer - Liner Pool Installation

(Part Nos: HD100SN Collar Weir or HD100N Flap Weir & HD100LAK)

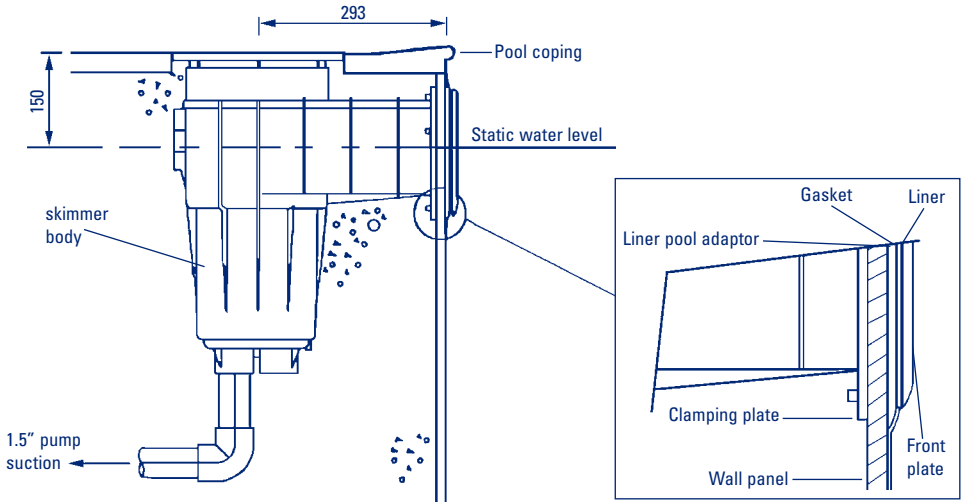

Spare port plugged with metric slip plug (HD8M)

## Wall Panel Aperture

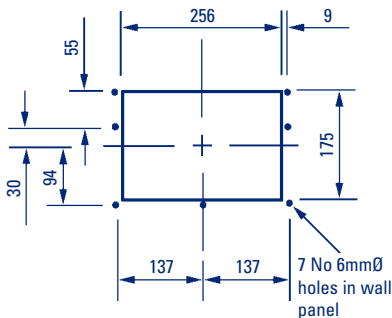

**Things To Remember**

- Ensure that skimmer is set square and level
- Debris and concrete should be prevented from entering skimmer unit during construction
- Liner adaptor plate should be used as a template for 7 No holds after aperture has been cut out
- Liner should be trimmed out as tightly to inside edge of skimmer throat as possible
- Any threaded connections should be made with PTFE tape, not liquid jointing
- To set your skimmer further back from the pool edge, Parallel extension throats are available
- **All pipework and pool fittings must be pressure tested before backfilling**

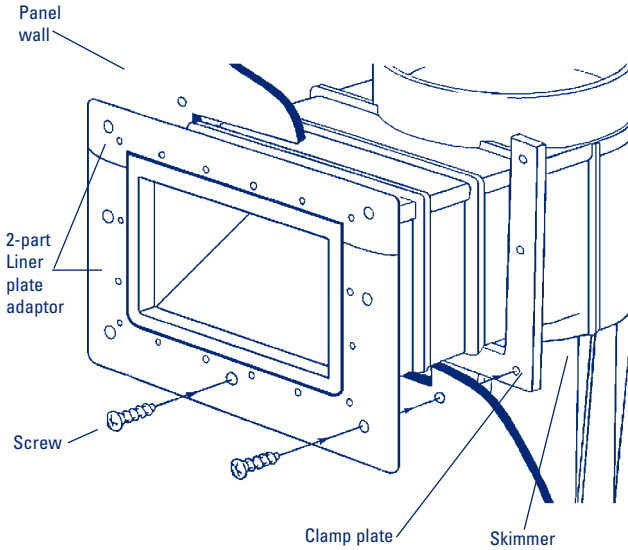

**1** Pass skimmer throat through panel wall aperture (see previous page for details) and clip 2-part liner plate adaptor onto recess on skimmer throat. Push skimmer back through wall until liner adaptor touches panel wall and all seven holes are aligned.

Slot clamp plate under skimmer throat and bring up to the wall forming a 'sandwich', ie liner plate adaptor - panel wall - clamp plate. Using screws provided, secure all parts together. NB, It is important that screws are tightened equally and are not over-tightened.

**2** Apply gasket to liner plate adaptor. After liner is in place, feel through liner for holes in gasket / liner plate adaptor and offer front finishing plate to skimmer throat ensuring all 16 holes are aligned. Using screws provided, secure front finishing plate to skimmer through pool liner and gasket. **Important Do not** use screws until water level has reached skimmer throat. Finish with white plastic caps.

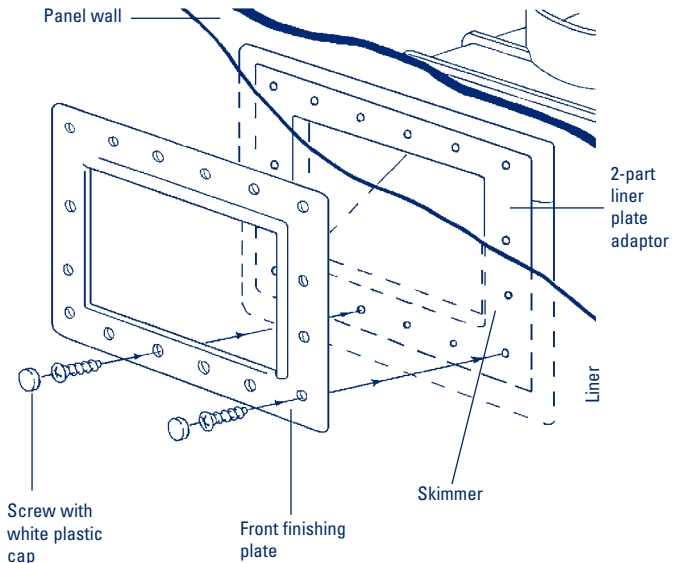

# Skimmer With Wide Angle Extension Throat - Panel Liner Pool Installation.

(Part Nos: HD100SN Collar Weir or HD100N Flap Weir & HD101LS Wide Angle Throat)

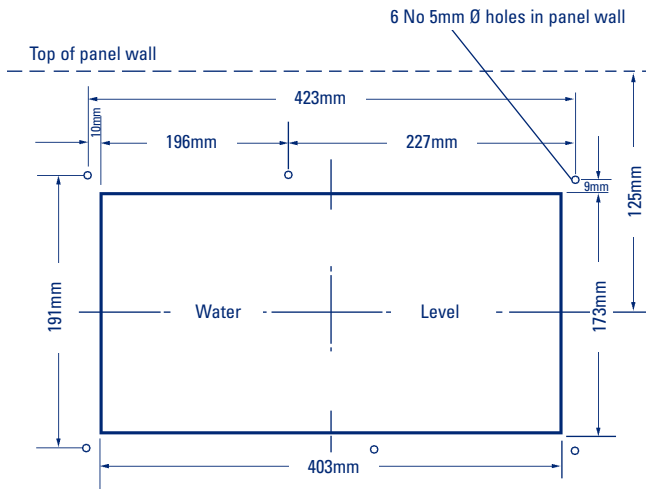

## 1 Details of panel wall aperture

Cut aperture in panel wall as per diagram. The front face of the wide angle throat can be used as a template for the 6 No 5mm holes (for holding screws) after the aperture has been cut out.

- 2 Pass wide angle extension throat into panel wall aperture from pool side and line up 6 holes in throat face with the 6 holes in the panel wall.

NB, ensure throat is the correct way up - 'top' is indicated on the throat. Attach the throat firmly to the panel using the 6 holding screws and nuts provided.

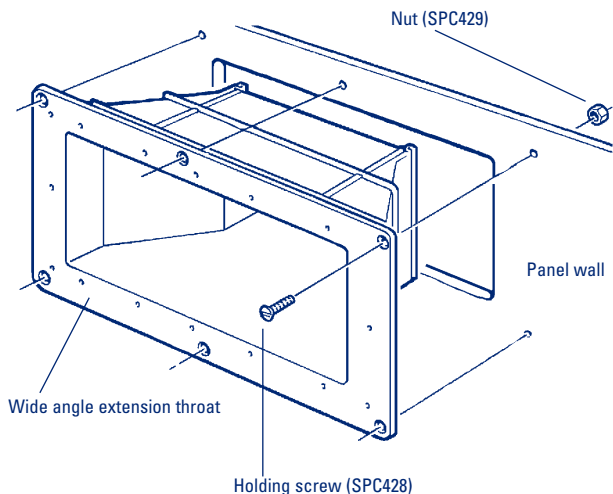

3

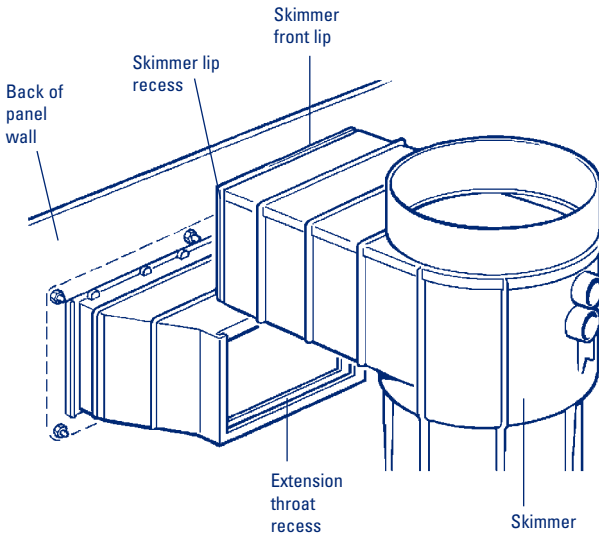

- 3** Using a brush, apply ABS cement to the front lip and recess of the Certikin skimmer and to the recess in the back face of the extension throat. Slot the skimmer lip down into the slot in the throat until firm. (The two holes in the base of the throat recess allow excess cement to squeeze out, ensuring an all-round fit). Using the brush, smooth off any other excess cement and re-coat the joins of the skimmer-throat inside and out, filling any voids to ensure a watertight seal.

- 4** Apply gasket to front face of extension throat.

**Important Do not fit liner clamp flange until water level has reached the level of the throat.**

After liner is in place, feel through liner for holes in gasket / throat face and offer clamp flange to throat ensuring all 16 holes are aligned. Using self-tapping screws provided, secure clamp flange to throat through pool liner and gasket.

Carefully cut liner material from centre of throat aperture. Finish using clip-on cover plate.

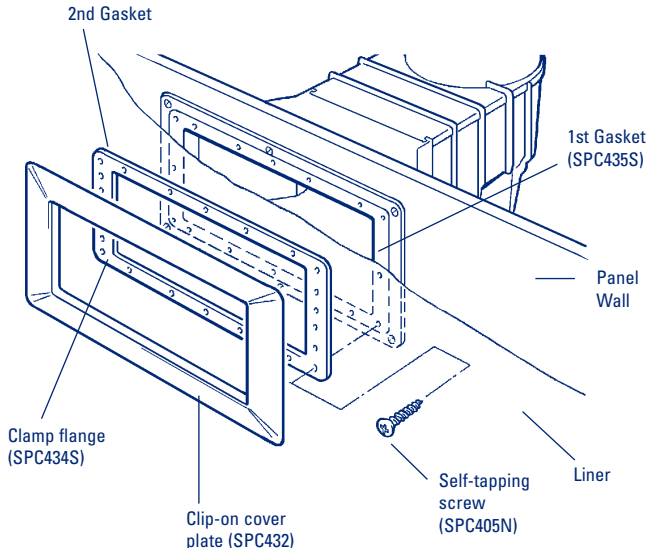

# Skimmer With Wide Angle Extension Throat - Concrete Pool Installation

(Part Nos: HD1001SCS Collar Weir or HD1001CS Flap Weir)

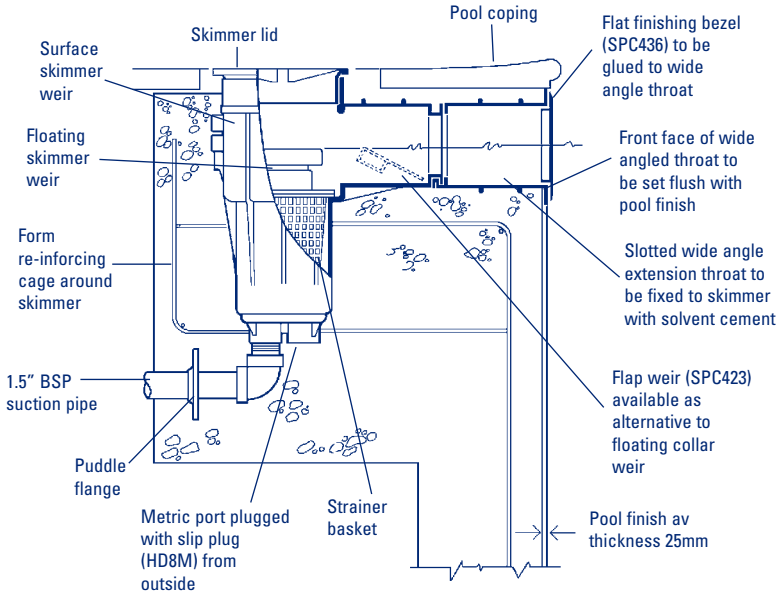

## Things To Remember

- Ensure that skimmer is set square and level. Slurry and concrete must be prevented from entering skimmer during construction.
- Use PTFE tape to make threaded joints. Liquid cement must not be used on threaded joints.
- **All pipework and pool fittings must be pressure tested before backfilling.**

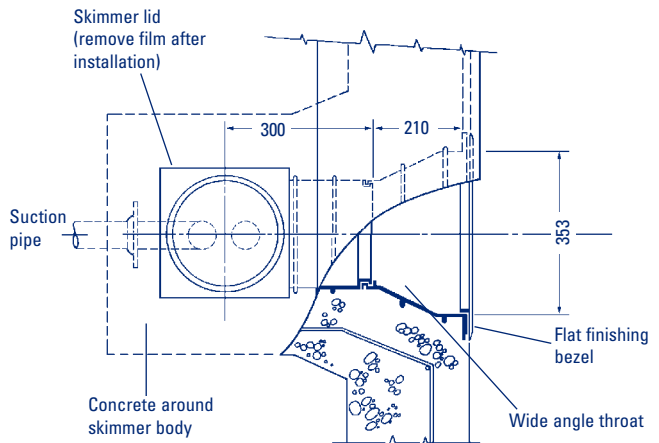

# Skimmer With Wide Angle Extension Throat - Concrete Block-Walled Liner Pool Installation.

(Part Nos: HD1001SLS Collar Weir or HD1001LS Flap Weir)

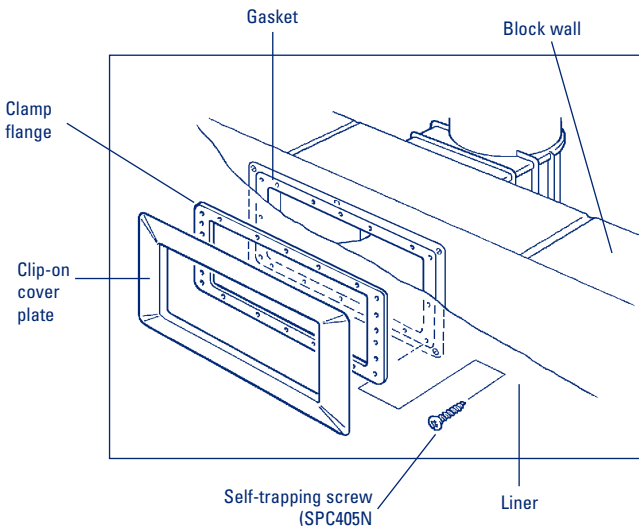
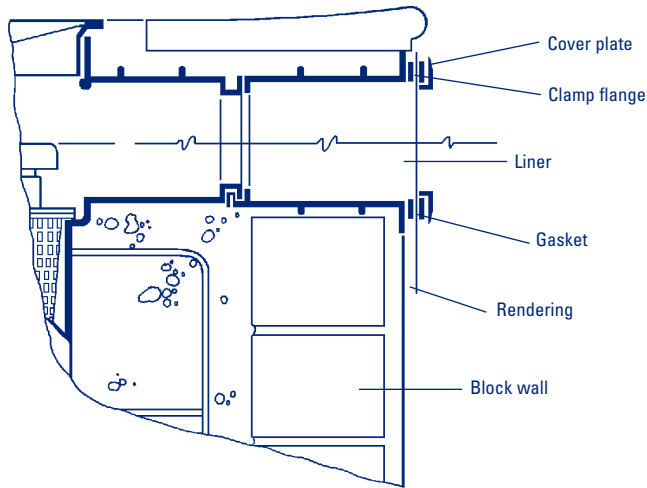

Apply gasket to front face of extension throat.

**Important Do not fit liner clamp flange until water level has reached the level of the throat.**

After liner is in place, feel through liner for holes in gasket / throat face and offer clamp flange to throat ensuring all 16 holes are aligned. Using self-tapping screws provided, secure clamp flange to throat through pool liner and gasket.

Carefully cut liner material from centre of throat aperture. Finish using clip-on cover plate.

# Skimmer - Concrete Pool Installation

(Part Nos: HD100SN Collar Weir or HD100N Flap Weir)

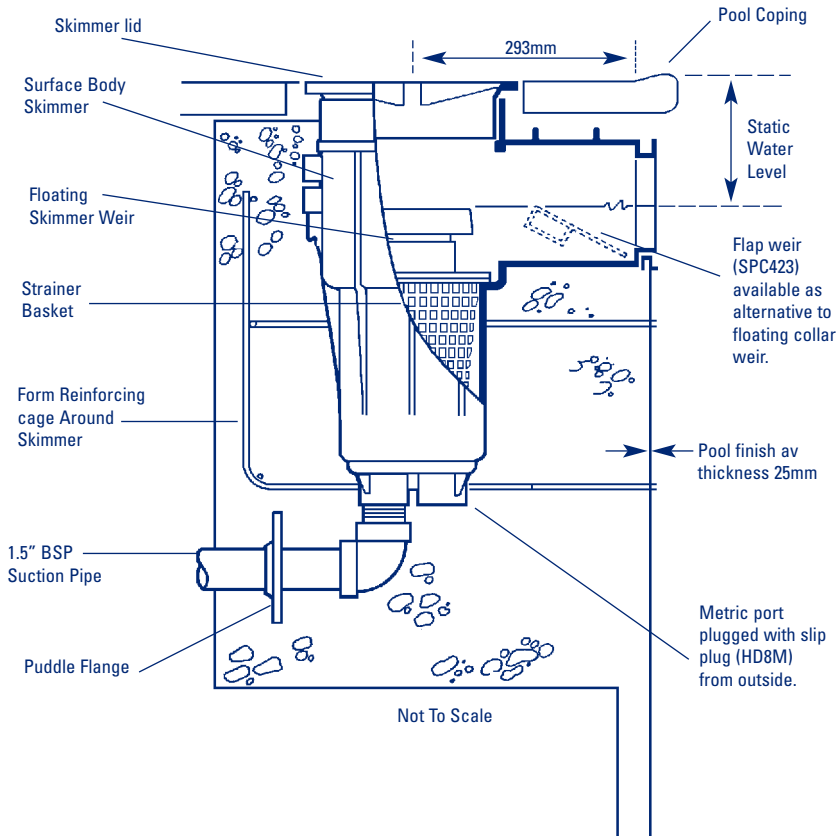

## ● Things To Remember

- All pipework and pool fittings must be pressure tested before backfilling
- Spare port plugged from inside with 1.5" BSP plug. Use PTFE tape to make threaded joints. Liquid cement must not be used on threaded joints
- Ensure that skimmer is set square level slurry and concrete must be prevented from entering skimmer during construction





**Certikin International,**  
Witan Park, Avenue 2,  
Station Lane Industrial Estate,  
Witney, Oxfordshire  
OX8 6FH  
United Kingdom

UK Tel: 01993 778855

UK Fax: 01993 778620

Export Tel: +44 (0) 1993 700744

Export Fax: +44 (0) 1993 708499

